

*Instructions for work
Betriebsanleitung*

*List of spare parts
Ersatzteilliste*



SIP

ROTO 275F

front rotary mower
front trommel mäher

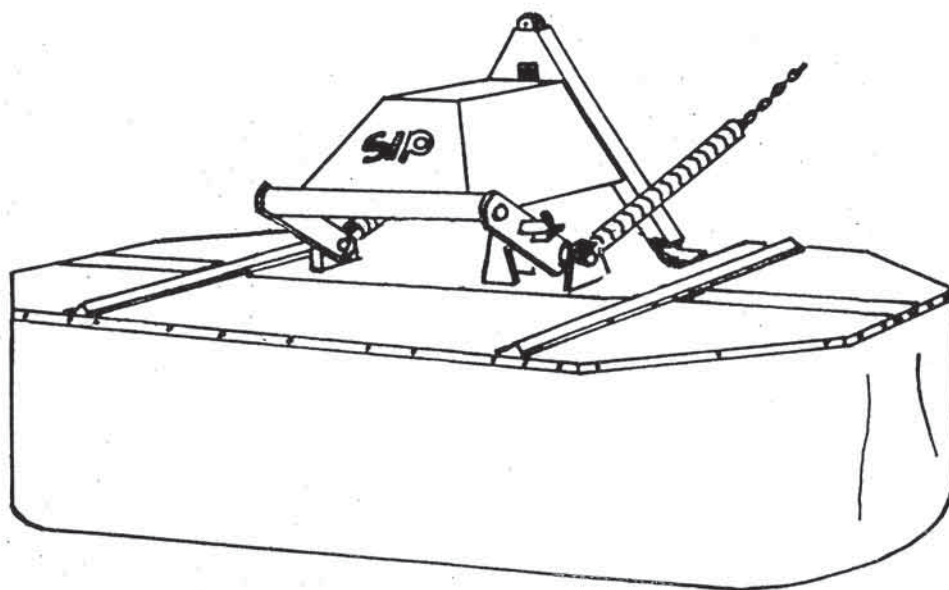

Valid from serial number on:
Gültig ab Maschinnummer:
ROTO 275 F = 041



SIP

STROJNA INDUSTRIJA d.o.o.
63311 Šempeter v Savinjski dolini
Slovenija

Tel: +386 (063) 702 211
Fax: +386 (063) 702 131
702 134

154000100

No.on the figure Numer anzeichn.	Catalogue no. Katalog nummer	Description	Benennung	Quantity Stück
2	153894003-551.05.018.0	Protection 2	Sicherung 2 schw.	2
3	153890311-551.03.000.1	Drive with drums	Antrieb mit Trommel	
4	153893503-551.05.008.0	Protection side	Sicherung seitlich schw.	2
6	153893318-551.05.006.1	Protection rear right	Sicherung seitlich recht	1
7	153893328-551.05.006.1	Protection rear left	Sicherung seitlich links	1
8	153893905-551.05.017.0	Protection side	Sicherung seitlich	2
9	153890810-551.00.002.1	Curtain	Forhänge	1
10	151798004-334.00.002.0	Plate	Platte	4
11	154049201-551.00.010.0	Curtain rear left	Forhänge hinten Links	1
12	153778503-543.04.020.0	Protection frame	Sicherunggerüste	2
14	154049309-551.00.010.0	Curtain rear right	Forhänge hinten recht	1
15	153778905-543.04.025.0	Link	Verbiendung schw.	2
16	153892710-551.04.026.1	Protection plate holder right	Blechträger recht	1
17	153892818-551.04.026.1	Protection plate holder left	Blechträger links	1
20	153780000-543.04.036.0	Bar 4	Schtange 4	2
21	153780108-543.04.037.0	Bolt	Bolzen	2
22	153780314-543.04.039.1	Pointer left	Geleichrichter links	1
23	153782116-543.04.058.1	Pointer right	Geleichrichter recht	1
24	000207902	Screw M6x20	Schraube M6x20	10
25	000250506	Nut M6	Mutter M6	10
26	000257108	Washer C6	Scheibe A12	10
27	150300301	Screw A 4,2x13	Schraube A 4,2x13	8
22	150143008	Screw M8x25 8.8 Zn	Schraube M8x25 8.8 Zn	20
29	000224108	Washer A8 Zn	Scheibe A8 Zn	22
30	150246004	Nut V M8 8 Cd	Mutter M8 8 Cd	24
31	000254101	Screw M8x25	Schraube M8x25	4
34	000238601	Cotter 3,2x20 Zn	Splint 3,2x20 Zn	4
36	150110203	Screw M10x50 8.8 Zn	Schraube M10x50 8.8 Zn	2
37	150084009	Nut M10 8 Cd	Mutter M10 8 Cd	2
38	151322900	Wire protection clamp 3	Sicherung drat 3	2
39	000210300	Screw M10x25 8.8 Zn	Schraube M10x25 8.8 Zn	8
40	000221307	Nut M10 8 Zn	Mutter M10 8 Zn	8
41	000228408	Washer B10 Zn	Scheibe B10 Zn	8
45	000248805	Screw M12x35 8.8 Zn	Schraube M12x35 8.8 Zn	2
46	000224509	Washer A12	Scheibe A12	2
47	000250604	Nut M12	Mutter M12	

Bild 18
Fig 18

Bild 18
Fig 18

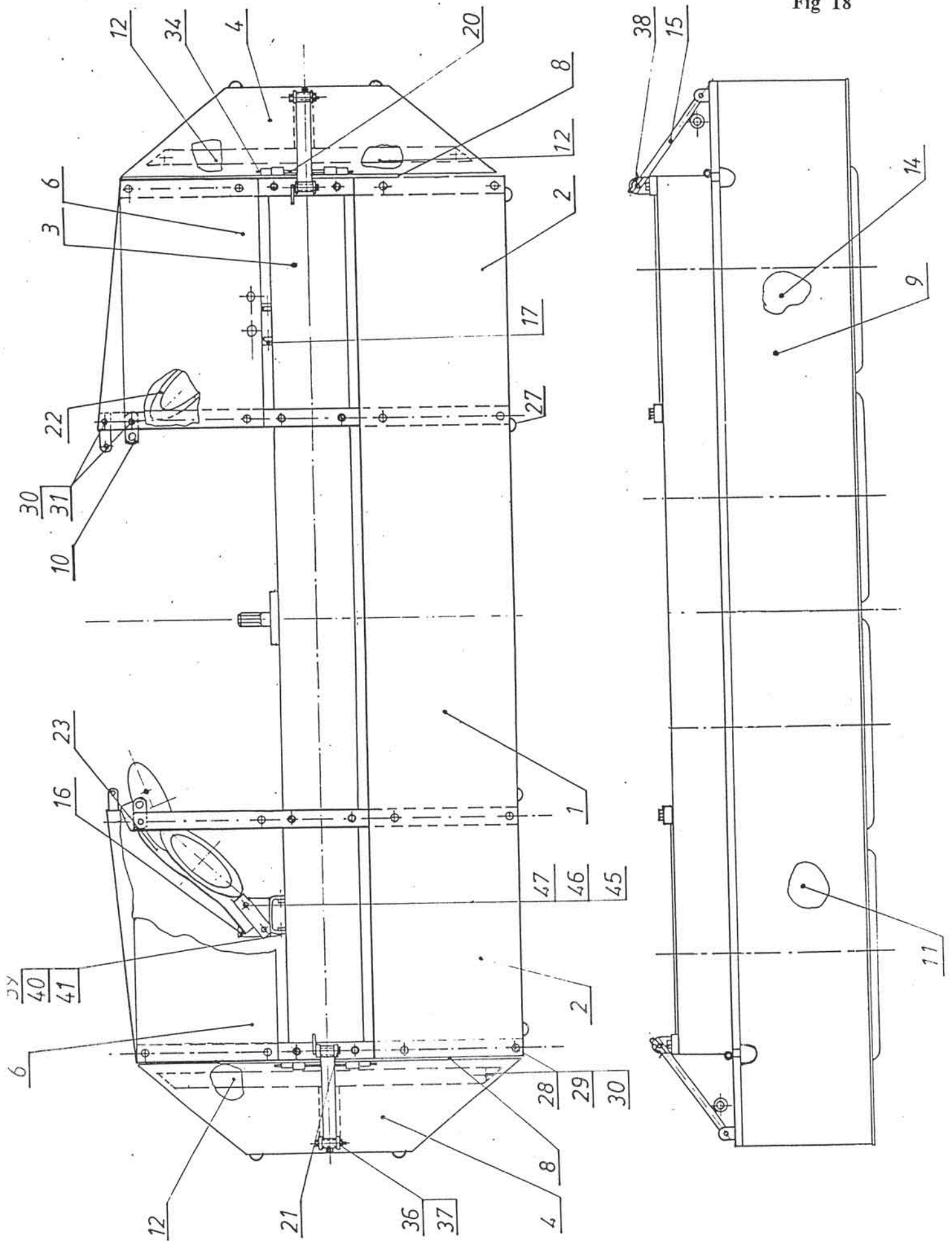

No.on the figure Numer anzeichn.	Catalogue no. Katalog nummer	Benennung	Description	Quantity Stück
1	154029205-543.04.080.0	Träger r.	Disc holder right	1
1	154029107-543.04.080.0	Träger l.	Disc holder left	1
2	154030006-543.04.087.0	Hand r.schw.	Right arm	1
2	154029900-543.04.087.0	Hand l.schw.	Left arm	1
3	154030701-543.04.093.0	Steuerscheibe	Guiding disc	1
4	154030505-543.04.091.0	Scheibe	Disc	1
5	154030603-543.04.092.0	Gummi scheinbe	Rubber disc	1
6	154029704-543.04.085.0	Lager gehäuse schw.	Bearing housing	2
7	154030907-543.04.095.0	Bolzen 7	Bolt 7	1
9	151233702-TN01	Unterlage 20,5/36-2	Washer 20,5/35-2	2
10	000242302	Lager KR 6204 RS	Bearing KR 6204 RS	4
11	000237103	Segerring 20	Circlip 20	2
12	151280802-600.04.078.0	Feder 2-2,5x12,5-152	Spring 2-2,5x12,5-152	1
13	000238905	Splinte 4x25	Coter 4x25	1
14	150404306-TN01	Schraube M8x25 8.8 Zn	Screw M8x30	4
15	000220905	Mutter M8	Nut M8	18
16	155409104	Federunterlage M8x25 8.8 Zn	Washer M8x25 8.8 Zn	10
17	150143008	Schraube M8x25 8.8 Zn	Screw M8x25 8.8 Zn	14
18	152521300-453.06.040.0	Unterlage 13,5x27x1,5	Washer 13,5x27x1,5	8
19	154029508-543.04.083.0	Scharier schw.	Neck	1

Bild 19
Fig 19

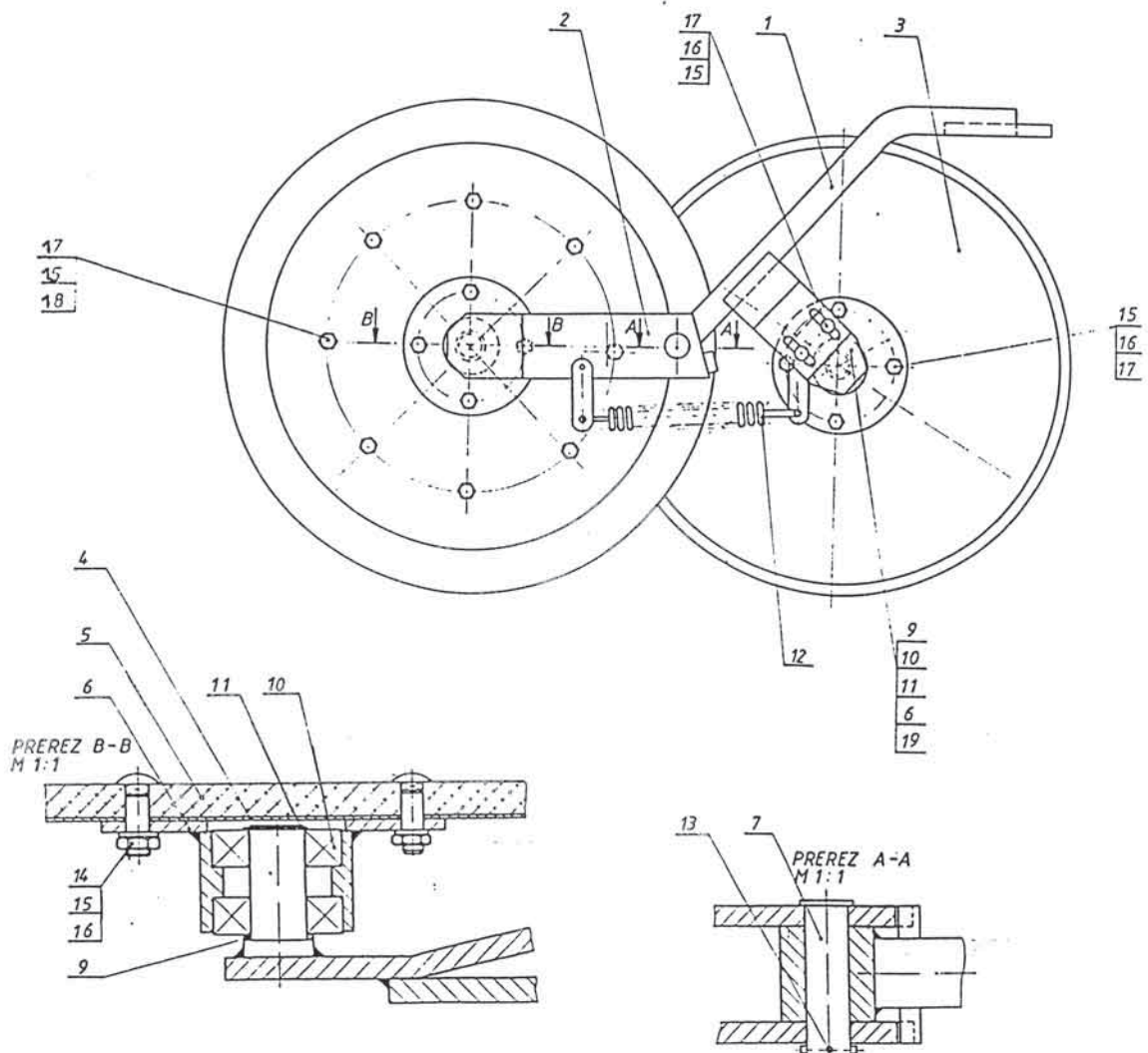

No. on the figure Numer anzeichn.	Catalogue no. Katalog nummer	Description	Benennung	Quantity Stück
1	153967005-543.03.078.0	Disc upper	Oberer teller	2
2	151033107-511.04.003.0	Disc lower	Unterer teller	4
3	153784408-543.03.065.0	Knife holder	Messer trärer	2
4	153136305-532.04.013.0	Key	Schlüsse	1
5	151018214-510.04.017.1	Flange	Flansche	4
6	151018400-510.04.018.0	Bearing housing	Lager gehäuse	4
7	152008615-516.04.019.1	Shaft	Welle	4
8	151018703-510.04.020.0	Distance tube	Distanzrohr	4
9	151018801-510.04.021.1	Pinion 15/4,4	Kegelrad	4
10	151018909-510.04.022.0	Screw	Schraube	24
11	151019007-510.04.023.0	Sleeve 25/57-14	Büchse 25/57-14	4
12	151019105-510.04.024.0	Sleeve 50/59-12,5	Büchse 50/59-12,5	4
13	151019203-510.04.025.0	Plate	Unterlagplatte	12
14	151019301-510.04.026.0	Protection plate	Sicherungblech	12
15	151019409-510.04.027.0	Protection rib	Sicherungblech	4
16	151019506-510.04.028.0	Screw M10x30	Schraube M10x30	12
17	151019604-510.04.029.0	Washer 73/109-3	Scheibe 73/109-3	8
18	153967103-543.03.120.0	Knife right	Messer recht	6
19	151019800-510.04.031.0	Elastic ring	Elastik ring	4
20	151019908-TN 01	Washer 35,2/43	Scheiben 35,2/43	
21	151020601-TN 01	Washer 50,2/58,5	Scheiben 50,2/58,5	
22	151015706-510.03.044.0	Protection washer	Sicherungscheibe	4
23	151012905-TN 01	Washer 25,2/33	Scheiben 25,2/33	
24	151014501-TN 01	Washer 50/61,8	Scheiben 50/61,8	
25	151021405	Nut M25x1,5	Mutter M25x1,5	4
26	153967201-543.03.120.0	Knife left	Messer links	6
27	153891212-551.03.001.1	Gear-box housing	Antriebsgehäuse	1
28	153770501-543.03.005.0	Shaft 1	Welle 1	1
29	153776006-543.03.061.0	Shaft 8	Welle 8	1
30	000257402	Screw M6x16 8.8	Schraube M6x16 8.8	8
31	000220503	Nut M6	Mutter M6	8
32	000222100	Nut M16	Mutter M16	24
33	153891310-551.03.007.1	Shaft 11	Welle 11	1
34	000227908	Washer B6	Scheibe B6	8
35	159770303	Oil seal O 30/34-2	Dichtung 30/34-2	2
36	000242909	Bearing KR 6305 2 RS	Lager KR 6305 2 RS 6	4
37	000244907	Bearing KR 6210 2 RS C3	Lager KR 6210 2 RS C3	8
38	000243908	Bearing KR 6207 2 RS	Lager KR 6207 2 RS	4
39	000255707	Bearing KR 51109	Lager KR 51109	4
40	159108805	Oil seal 50x72x8 BA	Simmerring 50x72x8 BA	2
41	150006102-SIMRIT	Oil seal 40x62x10 BA	Simmerring 40x62x10 BA	4
42	153890712-551.03.008.1	Sleeve 12	Büche 12	1
43	151013708-TN 01	Washer 30,2/38	Scheiben 30,2/38	
44	150390116	Key B8x7x32	Dübel B8x7x32	4
45	000256109	Key A8x7x55	Dübel A8x7x55	4
46	152007606-TN01	Washer 30,2/36	Scheiben 30,2/36	
47	154009904-543.03.125.0	Pinion 15/4,95	Kegelrad 15/4,95	2
48	000236300	Cirelip 62	Sicherungscheibe 62	4
49	000237602	Cirelip 62	Sicherungscheibe 62	4
50	150122307	Cirelip 28	Sicherungscheibe 28	2
51	000236505	Cirelip 72	Sicherungscheibe 72	2
52	150263208	Bearing KR 6206	Lager KR 6206	6
54	150106806	Screw M10x20 8.8 Zn	Schraube M10x20 8.8 Zn	24
55	150344700	Screw M10x30 10.9 Zn	Schraube M10x30 10.9 Zn	26
56	159624702-NBR.	Oil seal O 8/12x2	Dichtung O 8/12x2	1
57	150275400	Nut VM 10 8 Zn	Mutter VM 10 8 Zn	40
58	153775908-543.03.060.0	Pinion 23/4,42	Kegelrad 23/4,42	4
59	000228408	Washer B10	Scheibe B10	2
60	159059804	Oil seal 55/60x2,5	Dichtung O 55/60x2,5	2
61	151012503-45504.032.0	Plastic cover	Plastik deckel	2
62	150026519	Key B8x7x34	Dübel B8x7x34	6
63	153770903-543.03.010.0	Reinforcement	Verstärkerung schw.	2
64	153776104-543.03.062.0	Gear-box cover	Antriebs deckel	1
65	153891505-551.03.016.0	Holder	Träger schw.	2
66	154049407-551.02.027.0	Link	Verbiendung	2
67	153891917-551.03.030.1	Sleeve 7	Büchse 7	1
69	150406509	Key B8x7x39	Dübel B8x7x39	2
70	150377309	Screw M5x10	Schraube M5x10	5
71	159871506	Kemiskol VN 60	Kemiskol VN 60	
72	150200008	Washer A5	Scheibe A5	5
73	150325116	Bearing KR 6306 2 RS	Lager KR 6306 2 RS	2
74	154009806-543.03.126.0	Pinion 23/4,513	Kegelrad 23/4,513	2
75	159447501	Screw M14x30	Schraube M14x30	1
76	153892015-551.03.033.1	Sleeve 3	Büchse 3	1
77	153942407-543.03.075.0	Disc upper	Oberer teller	2
78	000224705	Washer A14	Scheibe A14	1

Bild 20
Fig 20

Bild 20
Fig 20

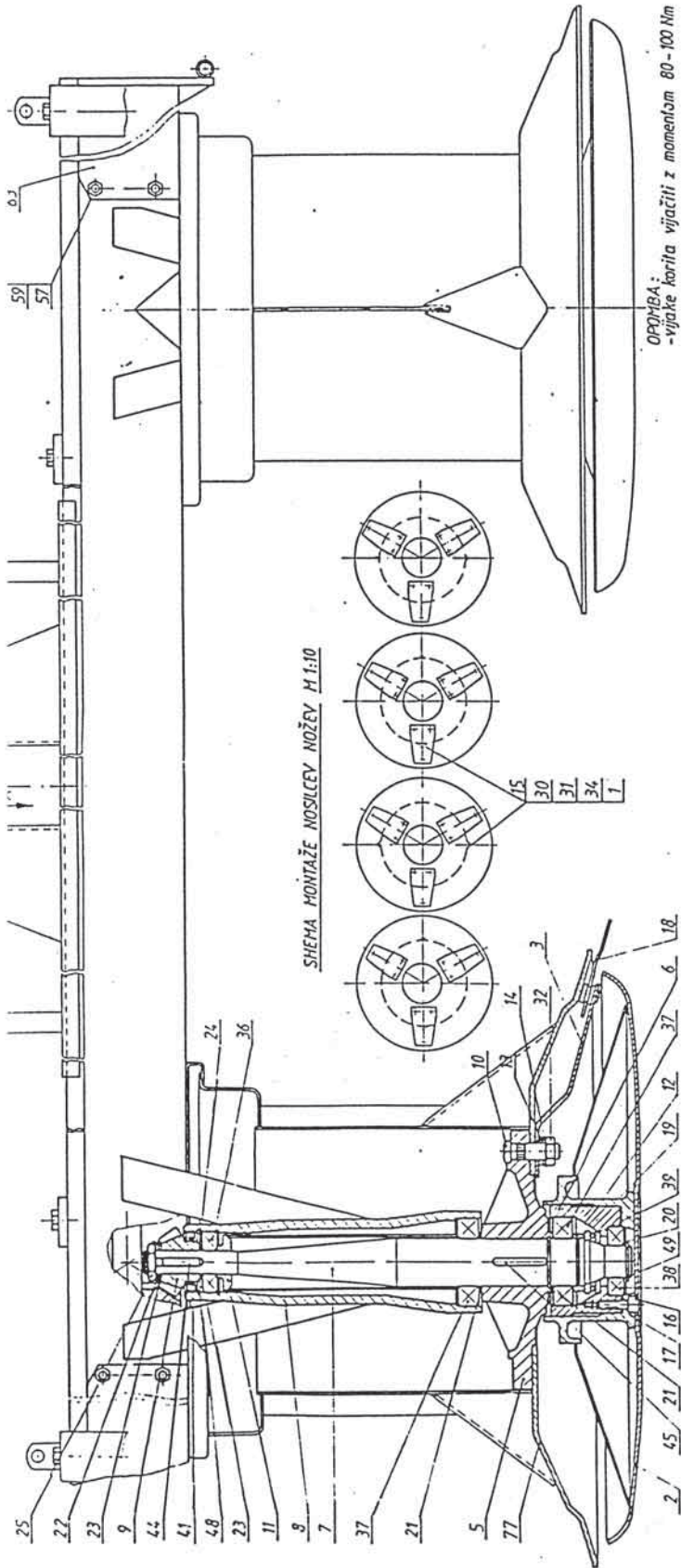

zobnik v oprjemu, MONTIRATI PO DIN - TRAKTOR: STEYR, FENDI, MF...ident 154001804. zobjnik v oprjemu, MONTIRATI PO ISO - TRAKTOR: ZETOR, ident 153906900

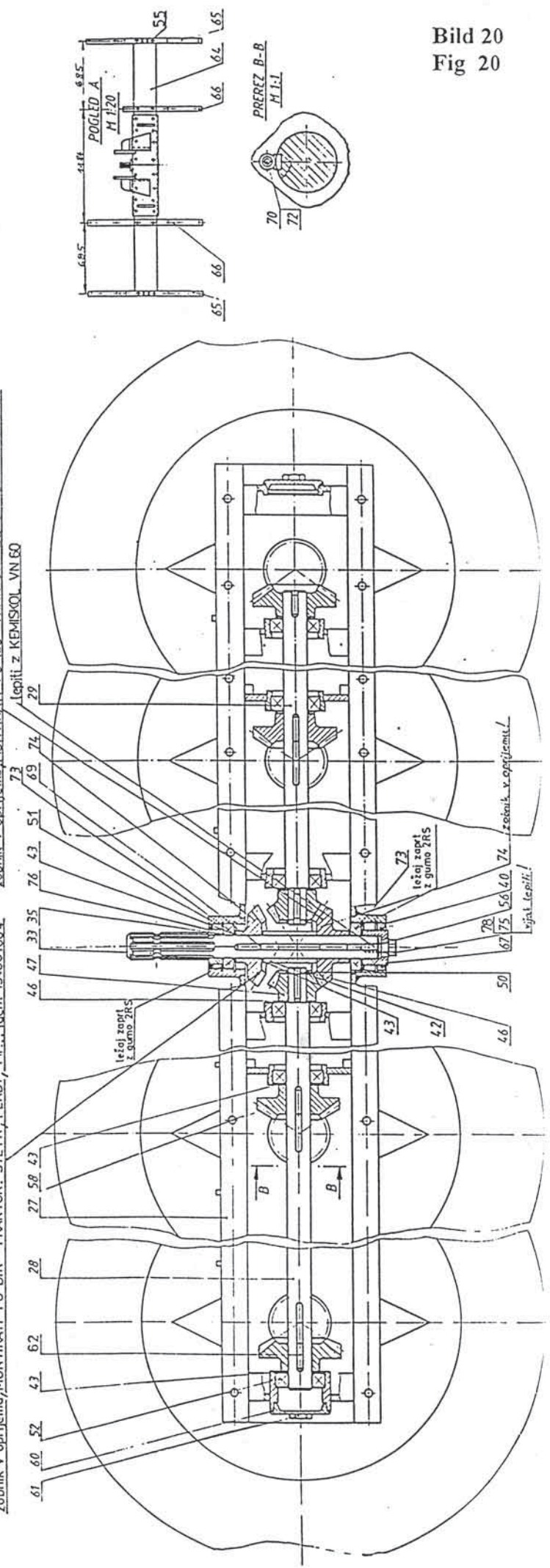

No.on the figure Numer anzeichn.	Catalogue no. Katalog nummer	Description	Benennung	Quantity Stück
1	153890614-551.00.001.1	Curtain	Vorhang	1
2	153167502-521.05.017.0	Rubber	Gummi kpl.	2
3	153890311-551.03.000.1	Drums cpl.	Trommeln kpl.	1
4	153892103-551.04.000.0	Hitch	Dreipunktaufhängung schw.	1
6	000246601	Lubricator M8x1	Schmier ippel M8x1	2
7	000240402	Cotter 5x50	Splint 5x50	2
8	000233401	Pin 6x36	Feder splint	1
9	153160108-521.00.011.0	Snap	Sicherung	1
10	151338500-650.00.012.0	Spring 3x25x80	Feder 3x25x80	1
11	150060908	Pin 10x70	Federstift 10x70	1
12	152378901-337.00.018.0	Handle	Ručica PVC grif	1
13	153890810-551.00.002.1	Curtain	Vorhang	1
14	153942504-543.02.070.0	P.T.O shaft protection	Gelenkwellen schutz	1
15	153160304-521.00.013.0	Bolt	Bolzen	1
16	000239405	Cotter 4x36 Zn	Splint 4x36 Zn	6
17	153159708-521.00.007.0	Linking bar.	Ferbindungs stange	2
18	153160402-PRIREZ	Tube	Rohr	1
19	153160509-521.00.015.0	Protector	Sicherung	1
20	000216705	Screw M10x30 5.6	Schraube M10x30 5.6	1
21	000258009	Nut M12 6	Mutter M12 6	1
22	150125509	Screw M12x50 8.8 Zn	Schraube M12x50 8.8 Zn	1
23	000250702	Nut M10 5.6 Cd	Mutter M10 5.6 Cd	1
24	153160206-521.00.012.0	Bolt	Bolzen	2
25	000207608	Screw M8x15 Zn	Schraube M8x15 Zn	8
26	150275204	Nut VM 6 Zn	Mutter VM 6 Zn	8
27	000226106	Washer 7 tip 1 Zn	Scheibe 7 tip 1 Zn	8
29	153160803-521.00.020.0	Chain Zn	Schikkette Zn	2
30	151180509-115.10.026.0	Linking glid.	Verbiendungs glied kpl.	6
31	000221307	Nut M10 8 Zn	Mutter M10 8 Zn	3
32	000228408	Washer B10 Zn	Scheibe B10 Zn	3
33	153890409-551.03.031.0	Protection	Schütz	1
34	153890409-551.03.031.0	Axle	Welle schw. B10 Zn	1
35	150300301	Screw A 4,2x13	Schraube A 4,2x13	10
46	153164104-521.04.007.0	Eye 1	Ohr. 1	2
47	153201403-521.00.025.0	Spring 10x34x530	Schpanungsfeder 10x34x530	2
48	153205604-521.00.026.0	Chain Zn	Kette Zn	2

Bild 21
Fig 21



Bild 21
 Fig 21

No.on the figure Numer anzeichn.	Catalogue no. Katalog nummer	Description	Benennung	Quantity Stück
1	154052107-551.02.044.0	Hitch	Anbau schw.	1
2	154052606-551.02.040.0	Front plate	Wand vorn schw.	1
3	154051108-551.02.001.0	Holder	Träger schw.	1
4	154051607-551.02.032.0	P.T.O.Shaft protection	Gelenkwelle sicherung	1
5	159445004	Screw M12x40 8 8 Zn	Schraube M12x40 8.8 Zn	4
6	000224509	Washer A12 Zn	Unterlage A12 Zn	4
7	150196004	Nut M12 8 Cd	Mutter M12 8 Cd	4
8	000253807	Screw M16x40 8.8 Zn	Schraube M16x40 8.8 ZN	4
9	000251505	Washer B16 Zn	Feder Unterlage B16 Zn	4
10	154052900-551.02.043.0	Protection	Schütz	1
12	150408400	Screw M12x80 8.8 Zn	Schraube M12x80 8.8 Zn	2
13	150408507	Shock absorber Ø80x60	Pämpfer Ø80x60	2
14	000209205	Screw M8x30 8.8 Zn	Schraube M8x30 8.8 Zn	3
15	000224108	Washer A8 Zn	Unterlage A8 Zn	5
16	000250800	Nut M8 5 Cd	Mutter M8 5 Cd	3
17	154049103-551.02.021.0	Sleeve	Lager Buchse	2
18	150160300	Nut M12 8 Zn	Mutter M12 8 Zn	6
19	000248903	Screw M8x20 8.8 Zn	Schraube M8x20 8.8 Zn	2
20	000228202	Washer. B8 Zn	Feder Unterlage B8 Zn	2
21	153160509-521.00.015.0	Protection	Sicherung	1
22	000216705	Screw M10x30 5.6	Schraube M10x30 5.6	1
23	000250702	Nut M10 5 Cd	Mutter M10 5 Cd	1
24	150125509	Screw M12x50	Schraube M12x50	1
25	000258009	Nut M12	Mutter M12	1
26	154054800-551.02.042.0	Protection 1 var.	Schütz 1.schw.	1
27	154055603-551.52.001.0	Curtain	Forhänge	1
28	154054908-551.02.035.0	Band 2	Zwischenstrebe 2	1
29	150246004	Nut M8	Mutter M8	3
30	150319809	Screw M8x35	Schraube M8x35	3
31	152592402-TN 03	Sleeve 1	Buchse 1	1
32	000207902	Screw M6x20	Schraube M6x20	6
33	000250506	Nut M6	Mutter M6	4
34	000257108	Washer C6	Unterlage C6	6
35	153167502-521.05.017.0	Rubber	Gummi	2
37	154079204-551.02.068.0	Hitch extention	Anbauverlengerung	1
38	154055202-551.02.060.0	Hitch cpl.	Anbau kpl.	1
39	154054409-551.52.002.0	Spring	Feder	2
40	154054506-551.52.003.0	Bolt	Bolzen schw.	2
41	154054301-551.52.005.0	Bolt	Bolzen	1
42	153888500-543.52.015.0	Chain	Kette kpl.	2
43	150272403	Tractor pin	Traktorbolzen	2
44	152015704-150.04.168.0	Wine safety damp	Kettesicherung	2

Bild 22

Fig 22

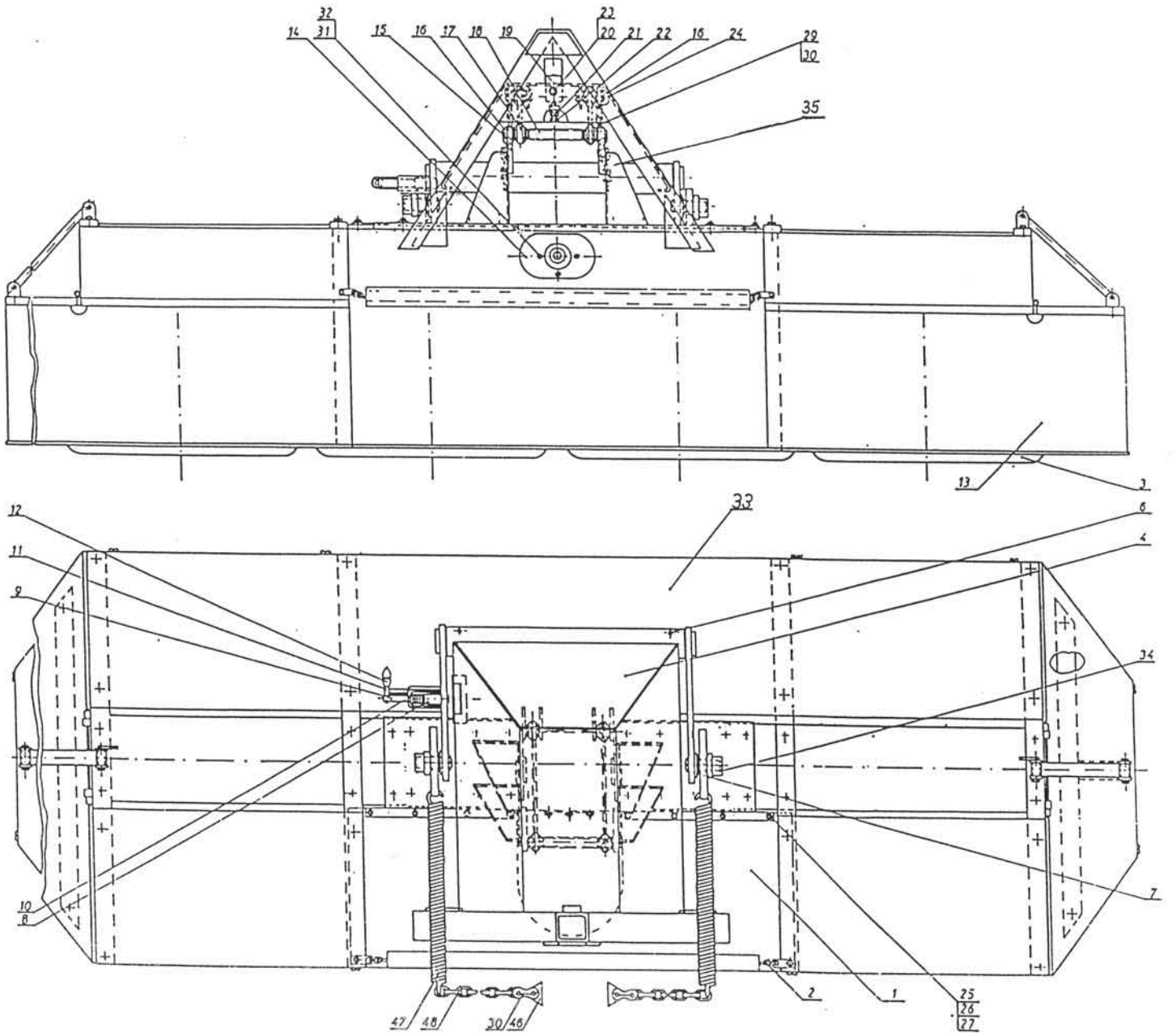
Bild 22
Fig 22

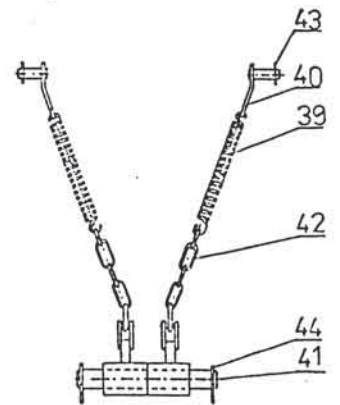
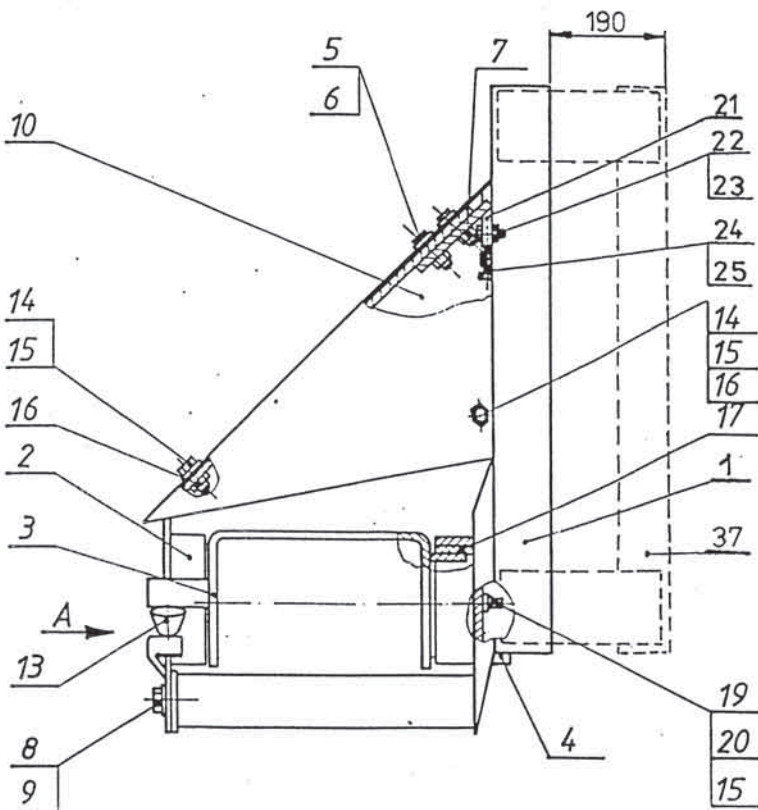
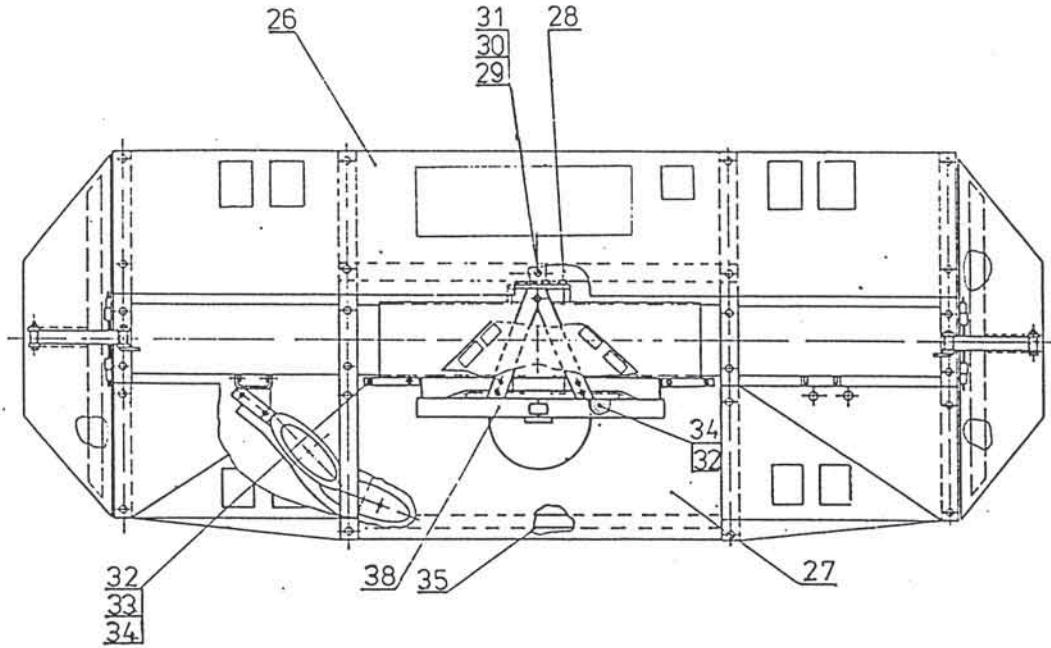
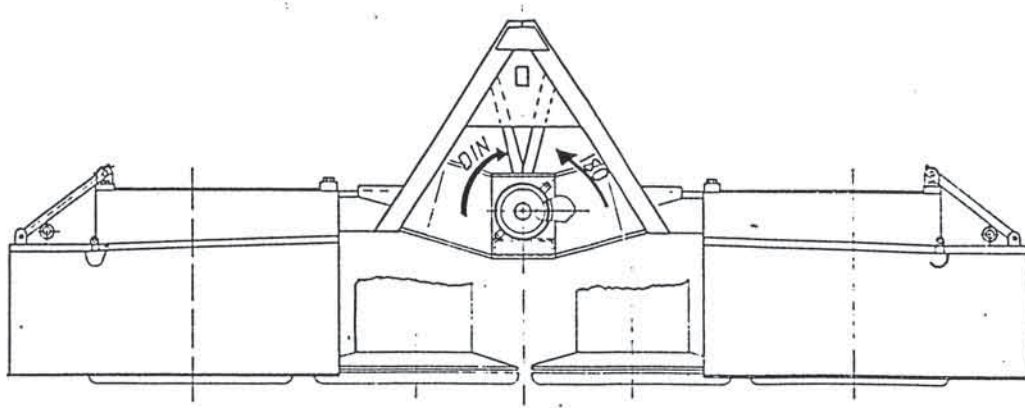

POGLED - A

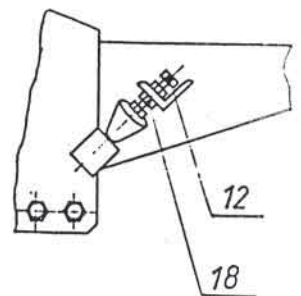

No. on the figure Numer anzeichn.	Catalogue no. Katalog nummer	Description	Benennung	Quantity Stück
1	154049504-551.02.002.0	Hitch	Anbaubock schw.	1
2	154050706-551.02.017.0	Front plate	Vorne Wand schw.	1
3	154051108-551.02.001.0	Holder	Träger schw.	1
4	154051607-551.02.032.0	P.T.O Shaft protection	Schutztrichter	1
5	159445004-	Screw M12x40 8.8 Zn	Schraube M12x40 8.8 Zn	2
6	000224509	Washer A12	Unterlage A12	2
7	150196004	Nut M12	Mutter M12	2
8	000253807	Screw M16x40	Schraube M16x40	4
9	000251505	Washer B16	Federunterlage	4
10	154052009-551.02.028.0	Tin plate right	Blech recht	1
11	154051901-551.02.028.0	Tin plate left	Blech links	1
12	150408400	Screw M12x80	Schraube M12x80	2
13	150408507	Shoch absorber Ø80x60	Dampfer Ø80x60	2
14	000209205	Screw M8x30 8.8 Zn	Schraube M8x30 8.8 Zn	3
15	000224108	Washer A8	Unterlage	5
16	000250800	Nut M8 5 Cd	Mutter M8 5 Cd	3
17	154049103-551.02.021.0	Sleeve	Lagerbuchse	2
18	150160300	Nut M12 8 Zn	Mutter M12 8 Zn	6
19	000248903	Screw M8x20 8.8 Zn	Schraube M8x20 8.8 Zn	2
20	000228202	Washer vzm.B8	Federunterlage B8	2
21	154055104	Hitch kpl.	Anbaubock kpl.	1
22	154054908-551.02.035.0	Band	Zwischenstrebe	1
23	152592402-TN 03	Sleeve 1	Buchse 1	1
24	154054800-551.02.042.0	Protection 1 var.	Schütz schw 1.	1
25	150319809	Screw M8x35	Schraube M8x35	3
26	150246004	Nut M8	Mutter M8	3

Bild 23
Fig 23

Bild 23
Fig 23

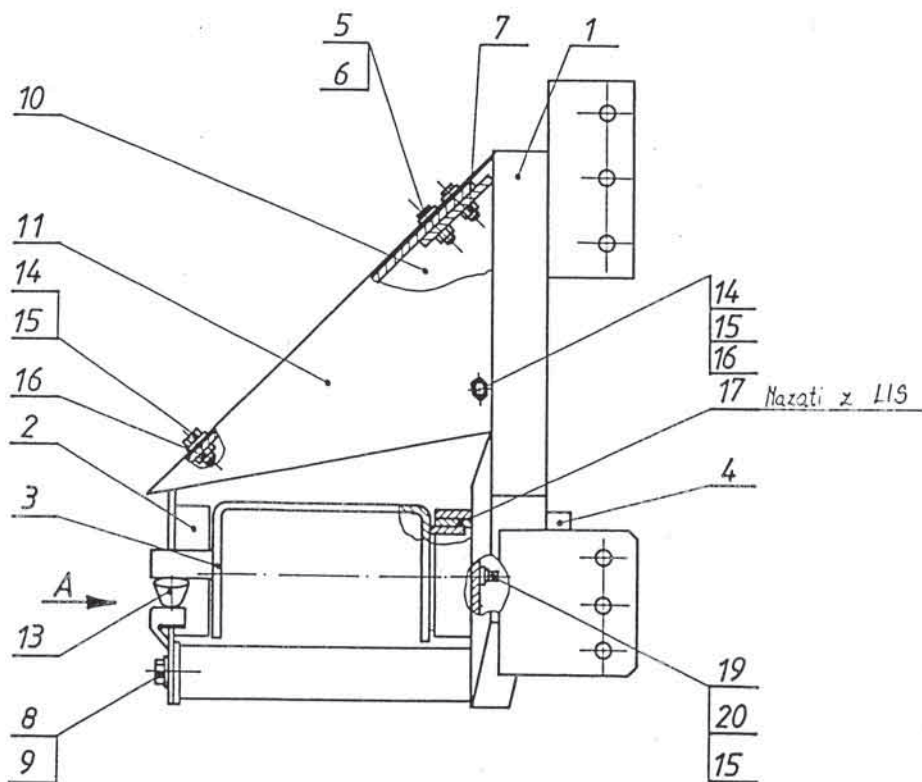
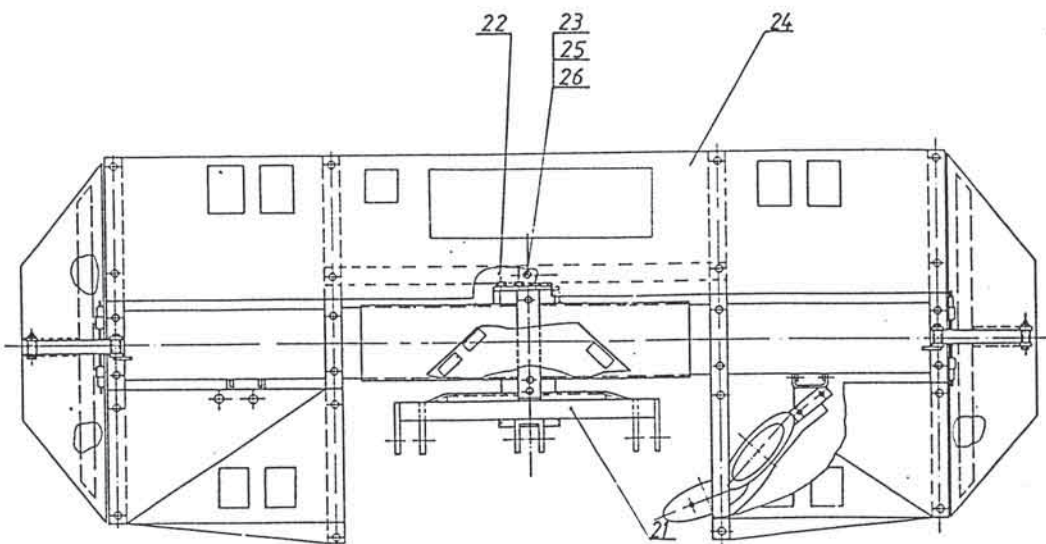
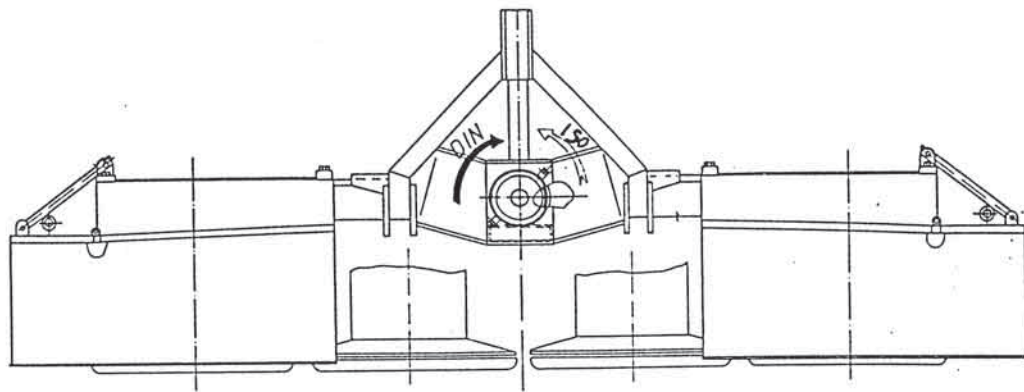

POGLED - A

